

MANUAL ALARM WITH RESET

FOR USE

ALL FIRE ALARM SYSTEMS UL/NFPA

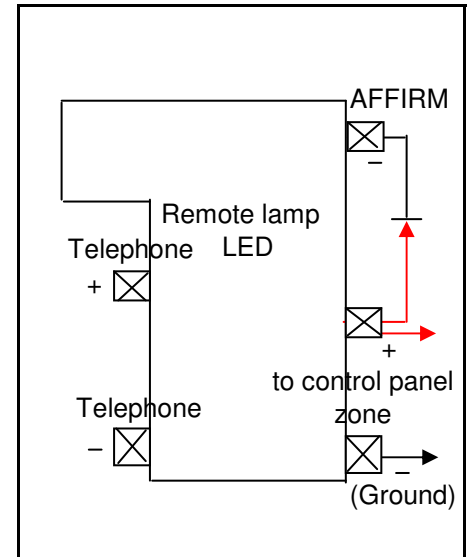

DUCUMENTATION

DATASHEET

This Fire Manual Station can quickly transmit a signal to the fire receiver terminals or the repeaters while the button under a transparent protective cover has been pushed at the first finding of a fire accident. (This signal is beyond the accumulated time limitation.)

There is a light over the button. The light will light up as a signal has been exactly received by the receiver terminal. There is also a telephone jack for telephone communication with attendant at the fire receiver terminal

FEATURE

- Reinforced transparent protective cover is reusable.
- All plastics are fire-proof, light, convenient and stylish.
- Auto-Return by pushing button, no need to disassemble the main body
- Outside cord distribution with terminators to ease on work.
- Response light available to identify the operation completed

SPECIFICATIONS

Model	FPE.CL-202
Input voltage	24VDC
Alarm current	DC, 100mA
Alarm confirm	red LED lamp
Size	14 (dia.) x 4cm
Model	FPE.CL-205
Boxbase	Size 14(dia) x 5 cm



**Model.FPE.CL-205
MANUAL ALARM BASE**

